

**Modular Cooking Range Line
 thermaline 80 - Full Module
 Freestanding Electric Fry Top with Mixed
 Plate, 1 Side, H=800**

ITEM # _____

MODEL # _____

NAME # _____

SIS # _____

AIA # _____



588406 (MAHFFAHDAO) Electric fry top with smooth and ribbed chrome plate, one-side operated

Short Form Specification

Item No. _____

Unit constructed according to DIN 18860_2 with 20 mm drop nose top and 70 mm recessed plinth. Internal frame for heavy duty sturdiness in 2 mm and 3 mm in 1.4301 (AISI 304). 2 mm top in 1.4301 (AISI 304). Flat surface construction, easily cleanable. THERMODUL connection system enables seamless worktop when units are connected and avoids soil penetrating. Chromium-plated mild steel cooking surface with non-stick finishing for optimal grilling. Features safety thermostat, thermostatic control and led indication of pilot flame. Electrical ignition powered by battery with thermocouple for added safety. Large drain hole allows draining of cooking juices into a large collector. Overheat protection switches off the supply in case of overheating. Metal knobs with embedded hygienic silicon "soft" grip enable easier handling and cleaning. IPX5 water resistant certification. Configuration: Freestanding, one-side operated.

Main Features

- Choice of one or two heating zones. An indicator lamp shows operating state of each zone.
- Large drain hole on cooking surface permits the draining of residual cooking juices into a large collector placed under the cooking surface.
- Overheat protection: a temperature sensor switches off the supply in case of overheating.
- Stainless steel high splash guards on the rear and sides of cooking surface.
- Units have separate controls for each half module of the cooking surface.
- All major components may be easily accessed from the front.
- THERMODUL connection system creates a seamless work top when units are connected to each other thus avoiding soil penetrating vital components and facilitating the removal of units in case of replacement or service.
- Metal knobs with embedded hygienic "soft-touch" grip for easier handling and cleaning. The special design of the controls prevents infiltration of liquids or soil into vital components.
- Large visible digital display manufactured in tempered glass to resist heat and chemicals, showing temperatures or power settings. The display also shows on/off status of the appliance and on/off status of the heating elements.
- Powerblock heating system for optimal temperature distribution.

Construction

- 2 mm top in 1.4301 (AISI 304).
- Unit constructed according to DIN 18860_2 with 20 mm drop nose top and 70 mm recessed plinth.
- Flat surface construction with minimal hidden areas to easily clean all surfaces
- Cooking surface in chromium-plated mild steel with non-stick finishing for optimum grilling results.
- IPX5 water resistance certification.
- Cooking surface 2/3 smooth and 1/3 ribbed.
- Internal frame for heavy duty sturdiness in stainless steel.

Sustainability

- Standby function for energy saving and fast recovery of maximum power.



APPROVAL: _____



Optional Accessories

- Connecting rail kit, 800mm PNC 912500
- Stainless steel side panel (12mm), 800x800mm, freestanding PNC 912508
- Stainless steel front kicking strip, 800mm width PNC 912598
- Stainless steel side kicking strips left and right, freestanding, 800mm width PNC 912619
- Stainless steel front kicking strip, 800mm width PNC 912634
- Stainless steel plinth, freestanding, 800mm width PNC 912825
- Connecting rail kit, right PNC 912971
- Connecting rail kit, left PNC 912972
- Endrail kit, flush-fitting, left PNC 913109
- Endrail kit, flush-fitting, right PNC 913110
- Scraper for smooth plates PNC 913119
- Scraper for ribbed plates PNC 913120
- Endrail kit (12mm) for thermaline 80 units, left PNC 913200
- Endrail kit (12mm) for thermaline 80 units, right PNC 913201
- Stainless steel side panel, left, h=800 PNC 913216
- Stainless steel side panel, right, h=800 PNC 913217
- INSERT.PROFILE,D800,TL-OTHER BRANDS PNC 913230
- - NOT TRANSLATED - PNC 913234
- - NOT TRANSLATED - PNC 913246
- - NOT TRANSLATED - PNC 913249
- - NOT TRANSLATED - PNC 913250
- - NOT TRANSLATED - PNC 913253
- - NOT TRANSLATED - PNC 913254
- - NOT TRANSLATED - PNC 913257
- - NOT TRANSLATED - PNC 913273
- - NOT TRANSLATED - PNC 913274
- - NOT TRANSLATED - PNC 913281
- - NOT TRANSLATED - PNC 913665
- STAINLESS STEEL DIVIDING PANEL 800X800MM LEFT/RIGHT PNC 913669
- ELECTRIC MAINSWITCH 25A 4mm² NM FOR MODULAR H800 ELECTRIC UNITS (FACTORY FITTED) PNC 913676
- - NOT TRANSLATED - PNC 913685

Recommended Detergents

- *NOT TRANSLATED* PNC 0S2292

Front

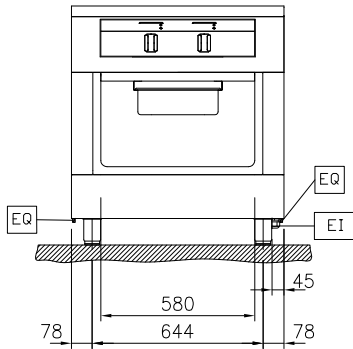

Side

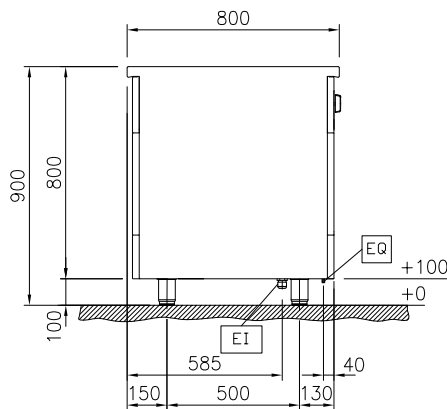

EI = Electrical inlet (power)
 EQ = Equipotential screw

Top

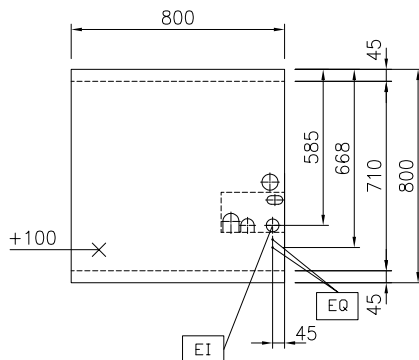
Electric

Supply voltage: 400 V/3N ph/50/60 Hz
 Total Watts: 15.3 kW

Key Information:

Cooking Surface Depth: 700 mm
 Cooking Surface Width: 615 mm
 Working Temperature MIN: 80 °C
 Working Temperature MAX: 280 °C
 External dimensions, Width: 800 mm
 External dimensions, Depth: 800 mm
 External dimensions, Height: 800 mm
 Storage Cavity Dimensions (width): 580 mm
 Storage Cavity Dimensions (height): 330 mm
 Storage Cavity Dimensions (depth): 740 mm
 Net weight: 150 kg
 Configuration: On Base; One-Side Operated
 Cooking surface type: Chromium Plated mild steel mirror

Sustainability

Current consumption: 22.1 Amps